

YAMUNA DENSONS Heat Shrinkable Dual Wall Tubing upto 66 kV

Features :

- Single Tube Solution
- Reduces time for installation
- Reduces skills
- Removes air entrapment caused by multi layer shrinking
- Ensures perfect bond between different layers
- Minimum shrink temperature: 110° C



Specifications:

Dimension Chart for Heat Shrink Dual Wall Tubing

Code	As Supplied	After Recovered	
	ø D1 (max.)	ø D2 (max.)	T (min.)
DDWT - 35/12	35	12	6.0
DDWT - 45/15	45	15	6.0
DDWT - 55/18	55	18	6.0
DDWT - 65/25	65	25	6.5
DDWT - 85/30	85	30	6.5
DDWT - 100/38	100	38	6.5
DDWT - 120/45	120	45	7.0
DDWT - 140/50	140	50	7.0

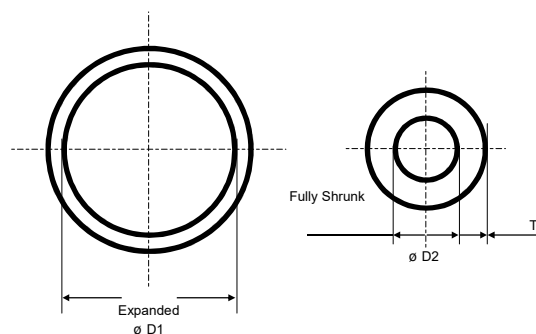

Note: All dimensions are in mm

Technical Data for Heat Shrink Dual Wall Tubing (for Inner Layer):

Property	Requirements	Test Method
Tensile Strength	8 N/mm ² (min.)	ASTM D 2671
Elongation at Break	200% (min.)	ASTM D 2671
Water Absorption	0.5% (max.)	ISO 62
Volume Resistance	10 ¹² Ω cm (min.)	IEC 93
Dielectric Strength	10 kV/mm (min.)	IEC 243

Technical Data for Heat Shrink Dual Wall Tubing (for External Layer):

Property	Requirements	Test Method
Tensile Strength	8 N/mm ² (min.)	ASTM D 638
Elongation at Break	200% (min.)	ASTM D 638
Water Absorption	0.5% (max.)	ISO 62